

MODELLO / MODEL
TEC200FBC

INFORMAZIONI TECNICHE / TECHNICAL INFORMATION

Massa base unità (corsa zero) Unit's base mass (zero stroke)	[Kg]	46
Massa lineare unità Unit's linear mass	[Kg/100 mm]	2,33
Massa secondo sfilo (corsa zero) Mass second extension (zero stroke)	[Kg]	8,9
Massa secondo sfilo (x 100 mm corsa) Mass second extension (x 100 mm stroke)	[Kg/100mm]	0,78
Massa primo sfilo (corsa zero) Mass first extension (zero stroke)	[Kg]	15,7
Massa primo sfilo (x 100 mm corsa) Mass first extension (x 100 mm stroke)	[Kg/100mm]	1,55
Velocità massima* Maximum velocity	[m/s]	4
Ripetibilità a vuoto Unloaded repeatability	[mm]	±0,15
Azionamento primo sfilo - secondo sfilo Drive first extension - second extension	Cremagliera/Cinghia Rack and pinion/Belt	
Tipo cremagliera** Rack features	Denti obliqui classe precisione Q7 Helix tooth accuracy class Q7	
Modulo ingranaggio primo sfilo Gear module first extension	3	
Sviluppo pignone Pinion primitive circumference	[mm/giro]	219,990

* I valori sono da considerarsi indicativi.
Prestazioni superiori sono possibili e vanno verificate col nostro ufficio tecnico.
Values should be considered as an indication.
Higher performance are possible. Please Contact our technical department.

** Disponibile su richiesta classe precisione Q6.
Available on request accuracy class Q6.

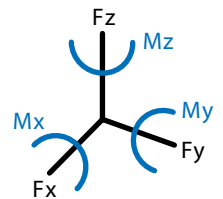
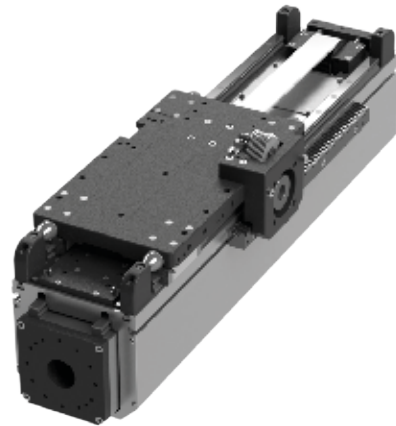

CARICO MASSIMO AMMISSIBILE / MAXIMUM PERMISSIBLE LOAD

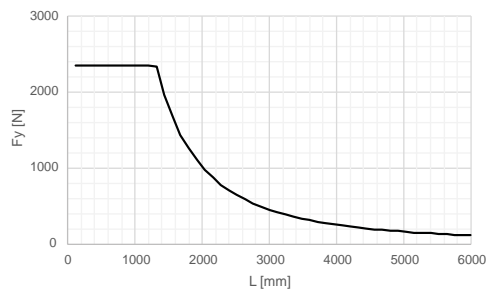
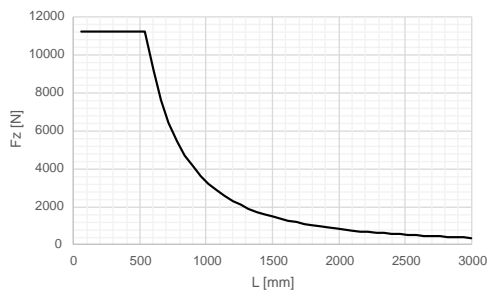

Sono rappresentati i carichi massimi applicabili in condizioni isostatiche, con vincolo rigido e carico all'estremità.
Maximum load in an isostatic cantilever loaded condition.

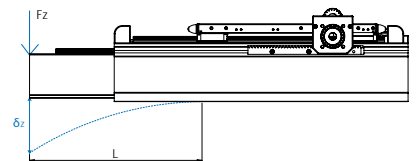

Accessori Accessories	Cinghia Belt	Vite Ball screw	Cremagliera Rack and pinion
① Riduttore Gearbox	x	x	x
② Kit assiale Axial kit	x	x	x
③ Calettatore Keyless Locking Device	x		x
④ Albero di torsione Torsion shaft	x		x
⑤ Carro aggiuntivo Additional carriage	x		x
⑥ Giunto elastico Elastic coupling	x		
⑦ Freno stazionamento Standing brake	x		
⑧ Elemento fissaggio/tassello Fastening/plug	x	x	x
⑨ Kit rinvio Transfer box	x	x	
⑩ Supporto sensore/Camma Sensor bracket/Cam	x	x	x

Le Unità Damo sono disponibili con una vasta gamma di accessori e optional specifici concepiti per facilitare la realizzazione e installazione di sistemi monoasse e multiasse.
All Units are available with a wide range of accessories and specific options designed to simplify the construction and installation of single-axis and multi-axis systems.

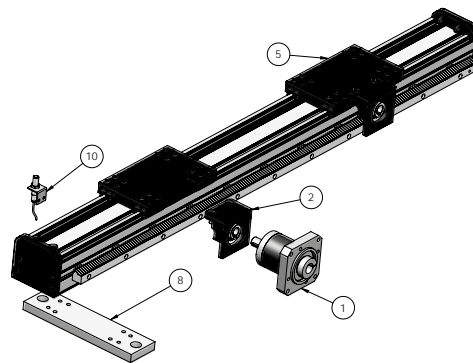

Si raccomanda di non superare i limiti dei grafici per non avere malfunzionamento dell'unità, peggioramento delle prestazioni o eccessiva usura.
We recommend not to exceed the maximum values to avoid lower performance, a reduced reliability and a big wear of the components.

DIMENSIONI / DIMENSIONS

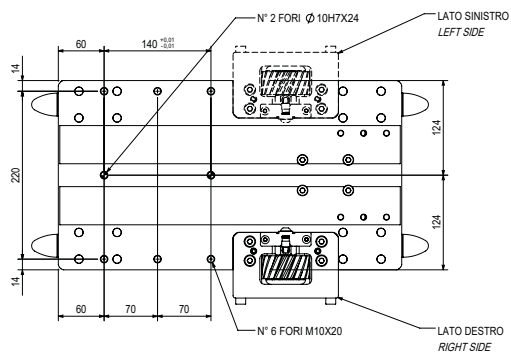
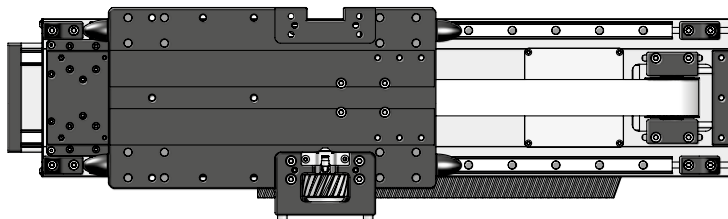
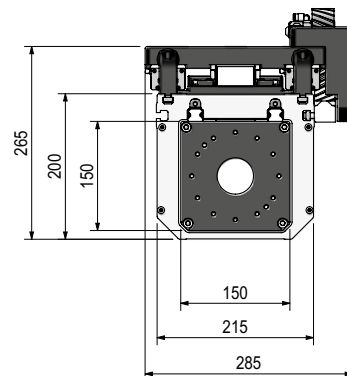
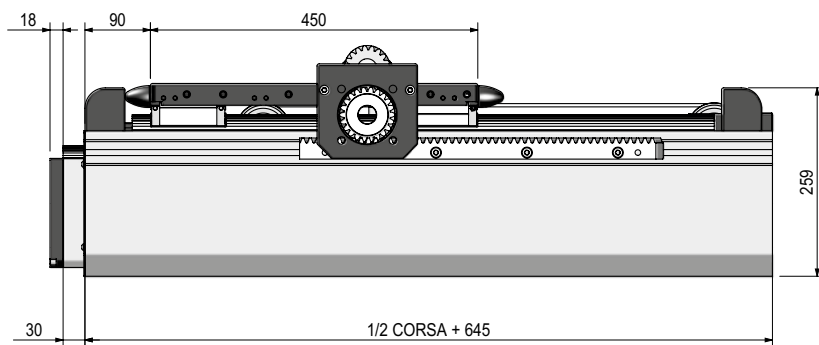

Tipologia interfaccia riduttore (2)
Gearbox interface type

Kit IF80

MODELLO / MODEL
TEC200FBC

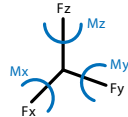

Sono rappresentate le deformazioni massime in condizioni isostatiche, con vincolo rigido e carico all'estremità. La deformazione effettiva dipende dalle condizioni di vincolo e dalla combinazione di carico.
Maximum deflection in an isostatic cantilever loaded condition. Actual strain depends on constraint condition and load combination.

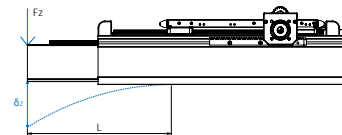

DEFORMAZIONE ELASTICA / ELASTIC DEFORMATION

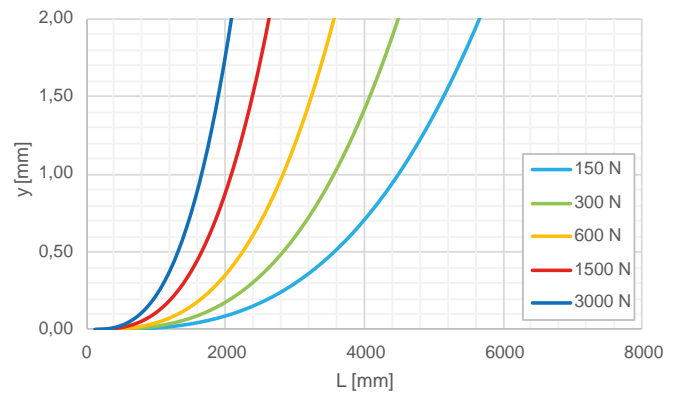
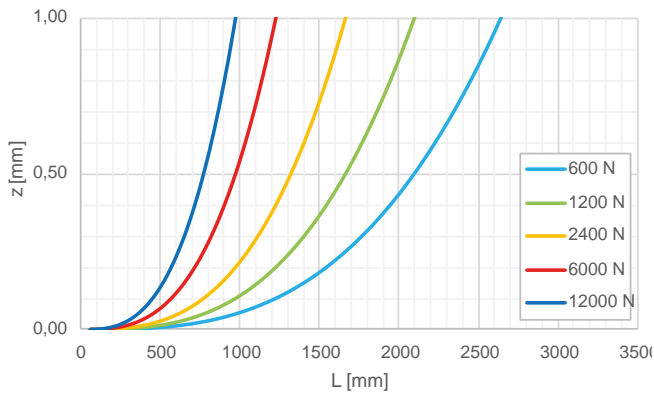

LIMITI STRUTTURALI / STRUCTURAL LIMITS

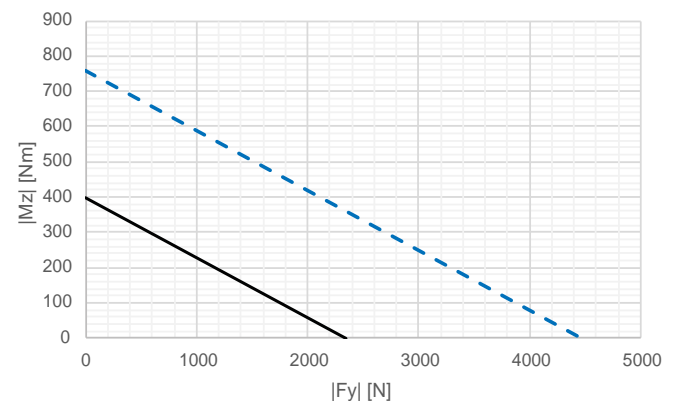
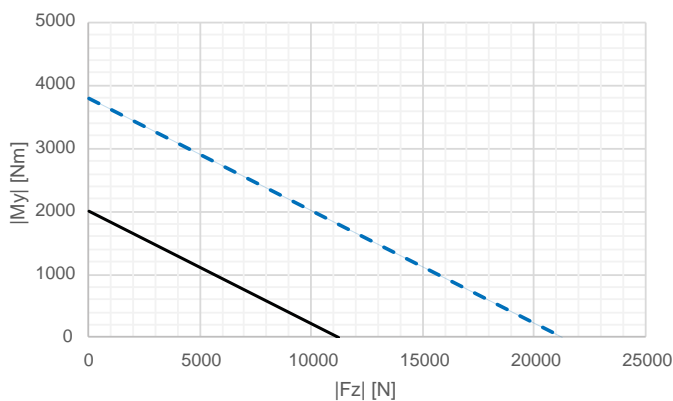

— Limite rottura a fatica: vita stimata superiore ai 10×10^6 cicli col 99% probabilità. I grafici non possono essere combinati e valgono per: $|Mx| \leq 0.1 |My|$ e $|Mx| \leq 0.1 |Mz|$.
Fatigue limit: estimated lifetime higher than 10×10^6 cycles with 99% probability. Charts cannot be combined and are valid for: $|Mx| \leq 0.1 |My|$ and $|Mx| \leq 0.1 |Mz|$.

--- Arresto d'emergenza max 100 volte nel corso della vita del prodotto.
Emergency stop max 100 times during service life.

Per casi di sollecitazione composta si faccia riferimento all'ufficio tecnico.
In case of combined stress contact our technical department.

